

[CONTRIBUTION FROM THE LABORATORY OF GENERAL CHEMISTRY, UNIVERSITY OF WISCONSIN]

## THE PREPARATION OF CHLORIDE FREE COLLOIDAL FERRIC OXIDE FROM FERRIC CHLORIDE<sup>1,2</sup>

BY C. HARVEY SORUM

RECEIVED OCTOBER 3, 1927

PUBLISHED MAY 5, 1928

### Introduction

Among the several theories of structure which have been advanced to account for the stability of colloidal ferric oxide is the so-called "complex" or "solution-link" theory. As recently discussed by Dr. Thomas of Columbia University<sup>3</sup> this theory proposes that the ferric oxide micelle is made up of two parts, an insoluble agglomerate consisting of  $x$  molecules of  $\text{Fe}_2\text{O}_3$  and a soluble attachment, a so-called "solution-link," consisting of  $y$  molecules of some soluble salt. In the case of colloidal ferric oxide prepared from ferric chloride the ferric chloride serves as the "solution-link." The empirical formula for the resulting micelle would be  $x\text{Fe}_2\text{O}_3 \cdot y\text{FeCl}_3$ .

Although Dr. Thomas does not give us the structural picture of his proposed micelle, we can readily visualize it as taking a form somewhat as follows: an insoluble nuclear mass consisting of  $x$  molecules of ferric oxide, and attached to this nucleus and radiating from it in all directions,  $y$  molecules of ferric chloride. The ferric chloride, being soluble in water, holds the insoluble ferric oxide nucleus in suspension. The  $x\text{Fe}_2\text{O}_3 \cdot y\text{FeCl}_3$  complex ionizes to give  $x\text{Fe}_2\text{O}_3 \cdot y\text{Fe}^{+++}$  ions and  $\text{Cl}^-$  ions. This would explain the positive charge on the colloidal particle as well as the various electrical properties associated with that charge.

The basic idea contained in the "solution-link" theory has been applied by numerous investigators,<sup>4</sup> particularly by Pauli and his co-workers<sup>5</sup> and by Wintgen and Löwenthal. They have accurately determined the amount of iron and chlorine in various samples of purified sol and from these analyses have proposed exact formulas for the micelle in each sol. Unfortunately there is no very close agreement among the twenty or thirty formu-

<sup>1</sup> The substance of this article was included in a paper presented at the Midwest Regional Meeting of the American Chemical Society, University of Chicago, May 27-28, 1927.

<sup>2</sup> An extract from a thesis presented in partial fulfillment of the requirements for the degree of Doctor of Philosophy, University of Wisconsin. All work was carried out under the direction of Professors F. C. Krauskopf and J. H. Walton, to whom the author is deeply and gratefully indebted.

<sup>3</sup> Thomas, *J. Chem. Educ.*, **2**, 323 (1925); Thomas and Freiden, *THIS JOURNAL*, **45**, 2522 (1923); Thomas and Johnson, *ibid.*, **45**, 2532 (1923).

<sup>4</sup> Weiser, "The Hydrous Oxides," McGraw-Hill Book Co., New York, 1926, p. 47.

<sup>5</sup> (a) Pauli and Walter, *Kolloidchem. Beihefte*, **17**, 256 (1923); (b) Kuhul and Pauli, *ibid.*, **32**, 319 (1925); (c) Pauli and Rogan, *Kolloid.-Z.*, **35**, 131 (1924).

las which they suggest. However, their formulas, even though they may vary widely, all agree in showing that some chloride is always present in colloidal ferric oxide derived from ferric chloride. In this respect their results bear out the conclusion, emphasized by numerous investigators, that the presence of chloride is not accidental but is a very necessary factor for stability.

Granting then, that chlorides are necessary for the stability of colloidal ferric oxide prepared from ferric chloride, the suggestion arises that, perhaps, if dialysis of impure sols were consistently carried to the very extreme limit of completeness, it should be possible to obtain stable colloids of constant iron-chlorine ratio. Such sols would then be the ultimate in ferric oxide stabilized by chloride and their behavior should be quite uniformly reproducible. To prepare such "ultimate" sols, determine their iron-chlorine ratio and study their behavior toward coagulating agents was the original object of some work undertaken in this Laboratory.

### Preparation of the Sol

Four hundred cc. of a molal solution of pure, resublimed ferric chloride was allowed to fall, drop by drop at the rate of two drops per second, into five liters of vigorously boiling distilled water contained in a six liter Pyrex flask.

The agitation resulting from the boiling ensured the complete and instantaneous mixing of the ferric chloride solution with the water. Increased temperature increases the rate and degree of hydrolysis, as does removal of the products. As carried out, the ferric chloride contained in a given drop of added solution would be hydrolyzed to the maximum degree before another drop entered the flask. We would thus come very close to having ferric oxide formed in the absence of free ferric chloride. Since increased temperature tends, generally, to decrease adsorption, high temperature hydrolysis should give colloidal ferric oxide with a minimum amount of adsorbed impurity.

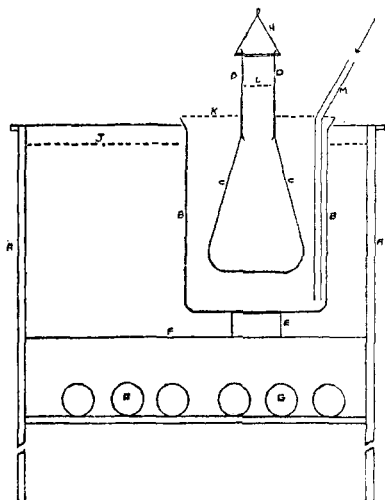

Fig. 1.

liter Pyrex beakers placed in a steam-heated water-bath the temperature of which was maintained at from 90 to 97°. Pure distilled water was allowed to flow through these beakers at the rate of about three liters per hour, an individual water tap being provided for each beaker. The distilled water was led in at the bottom of the beaker and allowed to overflow at the top, the overflow running into the water-bath and, finally, into the sewer drain. In each of these beakers was suspended a 250cc. collodion

### Purification of the Sol

A slight modification of the continuous method of hot dialysis, as first carried out by Neidle,<sup>6</sup> was employed. The dialyzer (see Fig. 1) consisted of a battery of twelve tall

<sup>6</sup> Neidle, *THIS JOURNAL*, 38, 1270 (1916).

bag containing impure sol, the bags being attached to two parallel lengths of one-inch glass tubing by means of copper wires fixed to the tops of the glass necks, D. The position of the suspended bag was so adjusted that the level of the overflowing liquid in the beaker was about one fourth of an inch above the bottom of the glass neck to which the bag was attached.

Dialysis was allowed to proceed continuously in the manner indicated and at the above mentioned temperature for periods varying from seven to twelve days. Before removal the contents of each collodion bag was tested for chloride in a manner to be explained later. In every case where dialysis was carried out for a week or more negative tests for chloride were obtained. Contrary to apparently unanimous results obtained by past workers<sup>7</sup> extreme dialysis, even when continued for five weeks at 90–97°, did not induce coagulation.<sup>8</sup>

The purified sols were deeply wine colored, clear to transmitted light, gave a strong Tyndall cone and showed no signs of precipitation even after twelve months. The iron content varied from 2.07 to 3.60 g. per liter.

### Discussion

The negative chloride tests mentioned above were entirely unanticipated and, in the face of an enormous amount of contrary evidence submitted by other investigators, certainly not to be expected. The probability of error immediately suggested itself, but the results were checked and rechecked, eighty-four independent samples of sol agreeing in giving negative chloride tests. The methods used in testing for chloride were as follows:

1. Twenty-five cc. of chloride free, concentrated nitric acid was added to 50 cc. of sol contained in a 250cc. Pyrex Erlenmeyer flask and set away at room temperature until all ferric oxide had dissolved to give a clear yellow solution of ferric nitrate. Five cc. of a saturated solution of silver nitrate was then added.

2. Twenty-five cc. of chloride free nitric acid was added to 50 cc. of sol contained in a flask. The contents were then warmed on the hot plate until all ferric oxide had dissolved, cooled and treated with 5 cc. of a saturated silver nitrate solution.

- 3 and 4. Methods 1 and 2 were repeated, sulfuric acid and silver sulfate being used in place of nitric acid and silver nitrate.

5. Method 2 was repeated, the nitric acid and silver nitrate both being added before the flask was heated.

6. Twenty-five cc. of concentrated sulfuric acid and 50 cc. of sol were placed in an all-glass retort, the contents of which were then heated to boiling. The distillate was collected in a cooled flask containing 5 cc. of a saturated solution of silver nitrate.

<sup>7</sup> Freundlich, "Colloid and Capillary Chemistry," Methuen and Co., Ltd., London, 1926, p. 374.

<sup>8</sup> A private communication from Dr. H. R. Kruyt, University of Utrecht, confirms the fact that extreme dialysis may not always induce coagulation. He reports that prolonged dialysis of sols in his laboratory did not result in their coagulation.

7. A liter of sol was evaporated to 48 cc. and tested as in Method 4. In each of the seven methods outlined, absence of turbidity after twelve hours was taken as evidence of absence of chloride.

Since the silver nitrate test is recognized to be an excellent test for chlorides, sensitive enough to be used in gravimetric analysis and nephelometry, the validity of the results obtained seemed beyond question. However, there remained the possibility that ferric ion could interfere. Any doubt on that score was, we feel, cleared up in the following manner.

The addition of one drop of 0.00931 *N* hydrochloric acid to 80cc. portions of the solutions which had given negative tests for chloride when treated according to the seven methods already outlined, gave a distinct turbidity, the addition of two drops gave a pronounced turbidity. The chloride was added as ferric chloride instead of hydrochloric acid, and the same results were obtained. Sols that were dialyzed for only three or four days gave positive turbidity tests, thus showing that chlorides, if present, would not evade detection. The average volume of the drops of 0.00931 *N* hydrochloric acid added was 0.04 cc. This means that the silver nitrate test, as carried out, is sensitive enough to detect the presence of 0.0000134 g. of hydrochloric acid per 80 cc. of solution, or 0.0001692 g. of hydrochloric acid per liter. The chloride content of the sols prepared, calculated as hydrochloric acid, must, therefore, have been less than 0.0001692 g. per liter.

If from among the twenty or thirty formulas for colloidal ferric oxide suggested by Pauli and his co-workers<sup>5c</sup> we select an average one, say,  $60.5 \text{ Fe}(\text{OH})_3 \cdot 5 \text{ FeOCl} \cdot \text{FeO}^+/\text{Cl}^-$ , we find that its Fe/Cl ratio is 3713.36/213. The most dilute sol prepared in the course of our study contained 2.07 g. of iron per liter. On the basis of Pauli's formula the chlorine content of such a sol should be 0.119 g. per liter. This is more than seven hundred times as much chlorine as can be detected by the silver nitrate test. We could divide and subdivide this value several times and still be within the limits of its sensitivity.

As such, the results indicate that the ferric oxide micelle, obtained by the hydrolysis of ferric chloride, is not a chlorine complex, a definite chloride compound. We would not venture the conclusion that the sols prepared were absolutely free from all  $\text{Cl}^-$  ions. There may be, and probably is, a slight trace of chloride present. However, this "trace," as shown by our sensitivity tests, must be less than 0.0001692 g. of hydrochloric acid per liter; and it hardly seems possible that such a small amount of electrolyte can be responsible for stability.

The suggestion arises that we may be dealing with a case of selective adsorption, that some other more readily adsorbable ion, nitrate for instance, may have completely ousted and replaced the chloride ion. However, no nitrate could be detected. To guard against any possible elec-

trolyte contamination, immaculate cleanliness was always observed. The collodion bags used in dialysis were always thoroughly rinsed with distilled water before being put into use. All glassware was steamed and rinsed.

A subsequent paper will deal with the properties of chloride free ferric oxide hydrosols.

### Summary

Stable ferric oxide hydrosols giving no test for chloride have been prepared by hydrolysis and hot dialysis of ferric chloride.

MADISON, WISCONSIN

---

[CONTRIBUTION FROM THE CHEMICAL LABORATORY OF THE UNIVERSITY OF OREGON]

## THE RELATION BETWEEN THE HYDROLYSIS EQUILIBRIUM CONSTANT OF ESTERS AND THE STRENGTHS OF THE CORRESPONDING ACIDS

BY ROGER J. WILLIAMS, ALTON GABRIEL AND ROY C. ANDREWS

RECEIVED OCTOBER 13, 1927

PUBLISHED MAY 5, 1928

The relationship has previously been mentioned<sup>1</sup> in comparing esters with mixed acid anhydrides, that esters of stronger acids are in general more completely hydrolyzed under like conditions than the esters of weaker acids. This generalization was based upon rather limited and in some cases questionable data, and it was therefore hoped to test out the generalization by obtaining more data on the hydrolysis equilibrium constants of esters of different acids.

It was planned to determine the equilibrium constants by the simple, direct method of heating the acid and alcohol together until equilibrium was established and analyzing the original and final mixtures. Unfortunately experimental difficulties prevented the determination of very many values by this direct method. The reactions are so slow even at 100° that it is necessary in order to reach equilibrium within any reasonable time to have a fairly high concentration of acid to act as catalyst in the final equilibrium mixture. Especially is this true in case a weak acid is being used. One of the principal difficulties introduced by reason of this fact is that of obtaining a homogeneous solution at equilibrium. In many cases sufficient acid for the catalysis will not remain dissolved. Another more or less obvious difficulty limiting the application of this direct method is the fact that "side reactions" are likely to occur. Many acids, for example, decompose under the conditions used before equilibrium in the esterification reaction is attained.

In spite of the fact that the work was not extended as far as it was at first hoped, some data contributing to the question were obtained and are here reported.

<sup>1</sup> Williams and Truesdail, *THIS JOURNAL*, **45**, 1348 (1923).